

SYNTHESIS 06/40 ELECTRIC CONVEYOR OVEN

2SV4411A



SPECIFICATIONS

Voltage	Trifase / Monofase - 230/400 Vac 50-60 Hz	
	Current at 220-240 V~	
	Current at 380-415 V 3N~	
Max Power	7900 Watts	
Weight	105 kg	
Plug Supplied	No, lead only	
Noise level	<70 decibels	
Conveyor Width	16" (400mm)	
Conveyor Length	1070mm	
Chamber Length	580mm	
Chamber Height	95mm	
Cable Length	2m	
Time Range	1:45 minutes - 30 minutes (or complete halt)	
Thermostat	320°C	
Ambient Temp	0- 40°C	
Warranty	4 Year Warranty (2 yr Labour 4 yr Parts)	



Main Features

- Made entirely from stainless steel
- Easy access for thorough cleaning
- Cooling system for contact parts
- Omnidirectional wheels with breaks (with stand accessory)
- Conveyor belt with variable speed down to a complete halt
- 95mm high cooking chamber
- Fine tuning of the ventilation flow
- Jets of hot air completely wrap the product as it moves along the wire mesh conveyor giving an evenly cooked result time after time
- All Synthesis ovens are stackable so you can step up your productivity to meet peak demand
- Total control of Top heating % Power and Bottom Heating % Power allowing total control.
- Management of 6 cooking programs: for each program you can set the cooking time, temperature and min/max adjustments to the power % of top / bottom Elements.
- Economy function keeps the oven at a lower temperature if it doesn't need to be operated at full working temperature
- Timer for programmed start, digital clock and self diagnostics

DIMENSIONS

External Width	1300mm	Internal Width	580mm
External Depth	980mm	Internal Depth	400mm
External Height	440mm	Internal Height	95mm

ACCESSORIES

Stand to suit



Phone: 1800 183 818 Email: support@thegoodlady.com.au
Website: www.thegoodlady.com.au

SYNTHESIS 06/40 SINGLE STACK CONVEYOR



FRONT

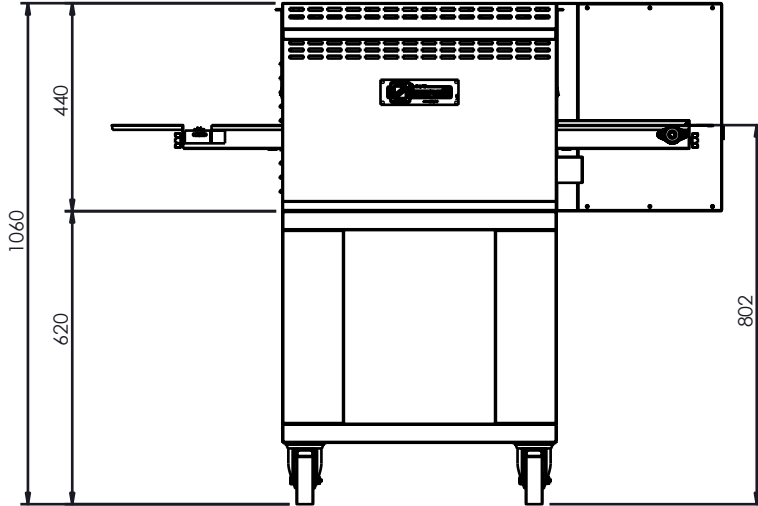

SIDE

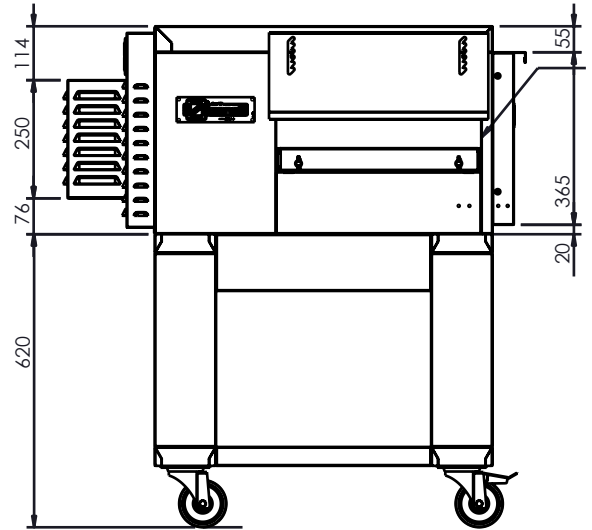

Num. articolo	Quantità	Descrizione	Potenza
11		0SV2A13	7.7KW Power
21		2SV4411	

TOP

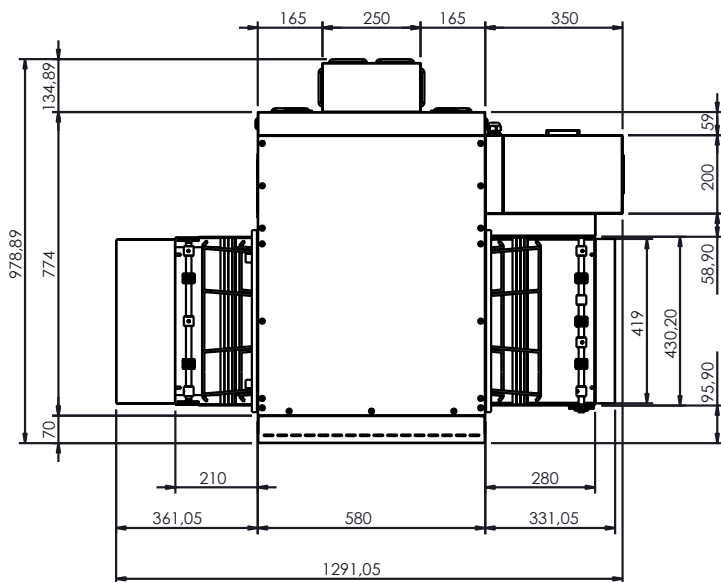

REAR

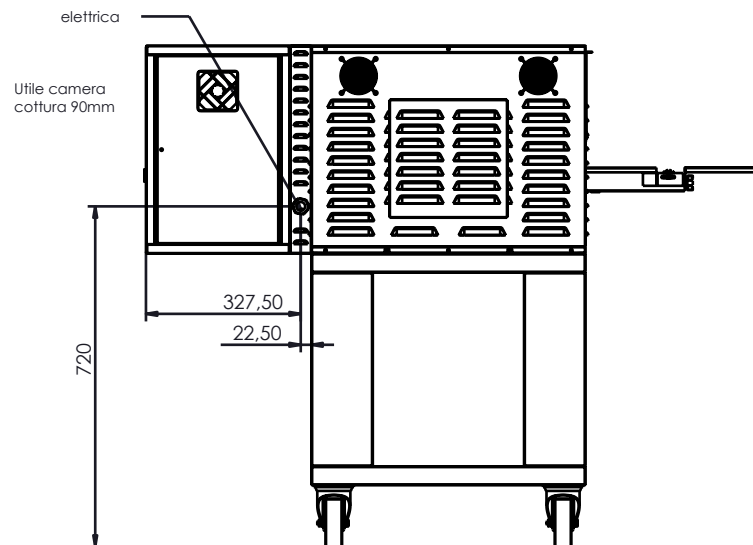

We reserve the right to alter specifications without notice.



THE GOOD LADY

Phone: 1800 183 818 Email: support@thegoodlady.com.au
Website: www.thegoodlady.com.au

SYNTHESIS 06/40 DOUBLE STACK CONVEYOR



FRONT

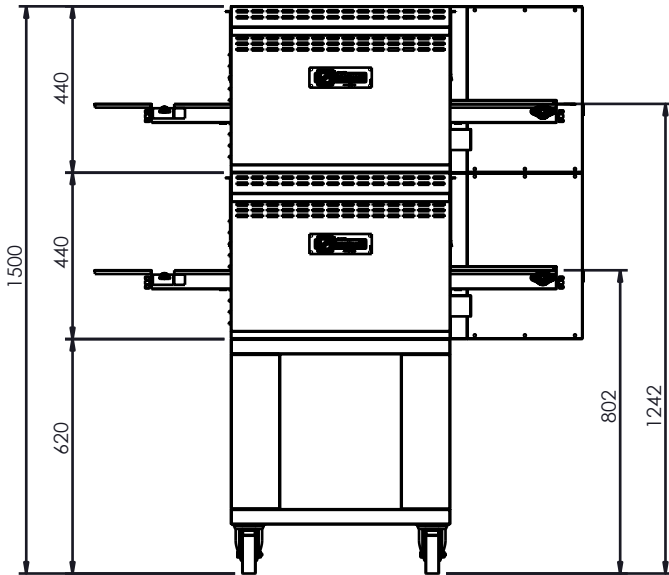

Num. articolo	Quantità	Descrizione	Potenza
11		0SV2A13	
22		2SV4411	7.7Kw+7.7Kw Power

SIDE

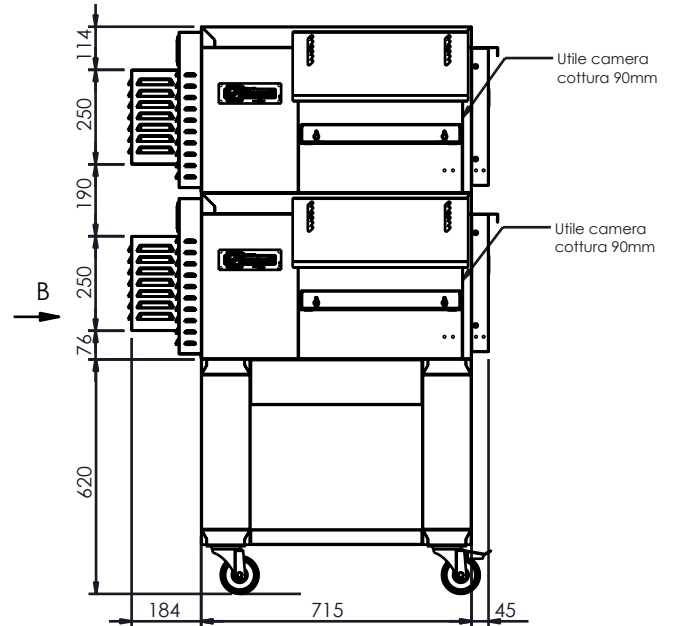

TOP

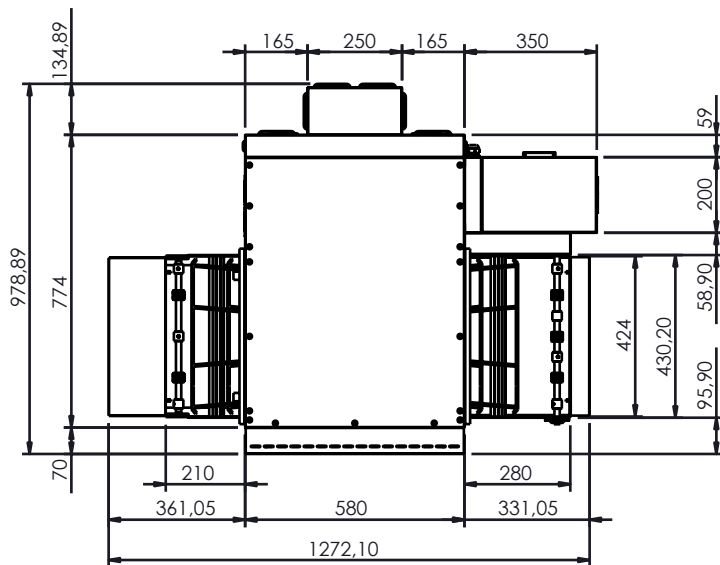

REAR

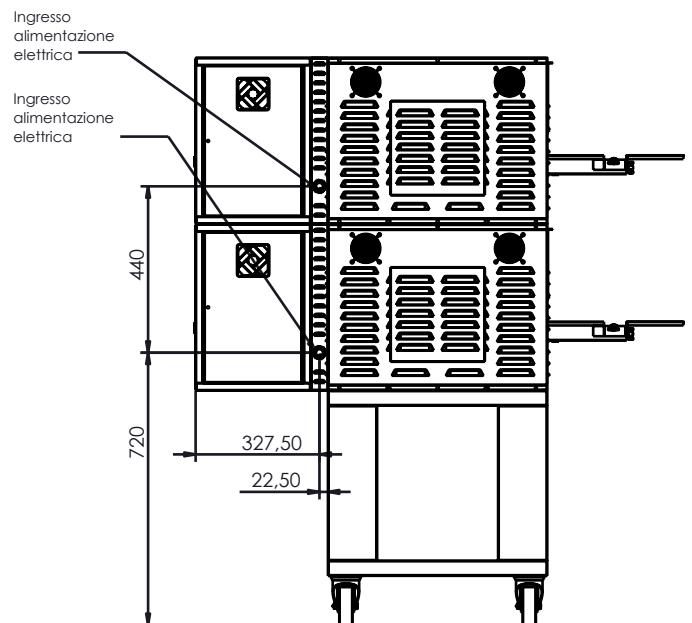

We reserve the right to alter specifications without notice.



THE GOOD LADY

Phone: 1800 183 818 Email: support@thegoodlady.com.au
 Website: www.thegoodlady.com.au

SYNTHESIS 06/40 TRIPLE STACK CONVEYOR



FRONT

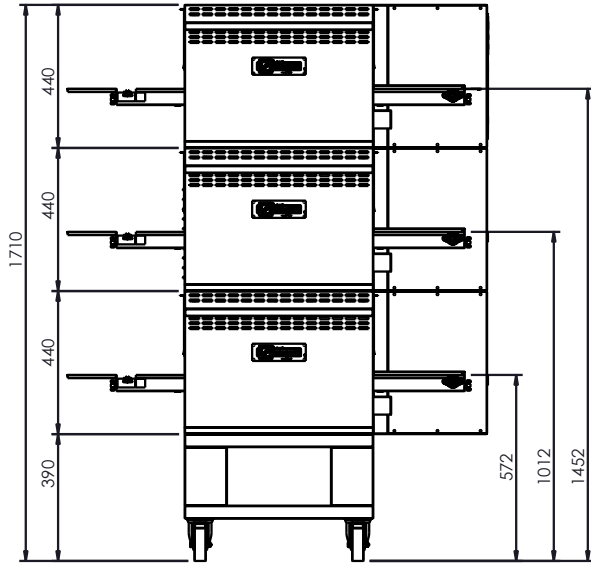

Num. articolo	Quantità	Descrizione	Potenza
11		0SV2A16	
23		2SV4411	7.7Kw+7.7Kw+7.7Kw Power

SIDE

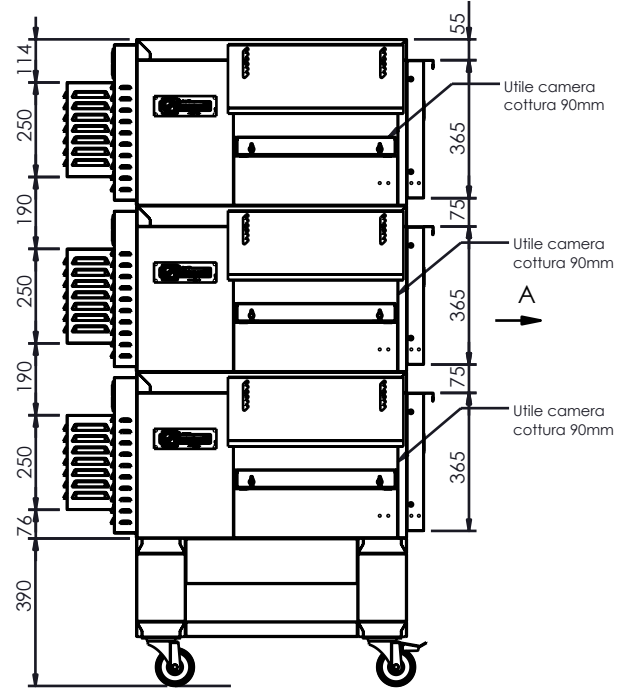

TOP

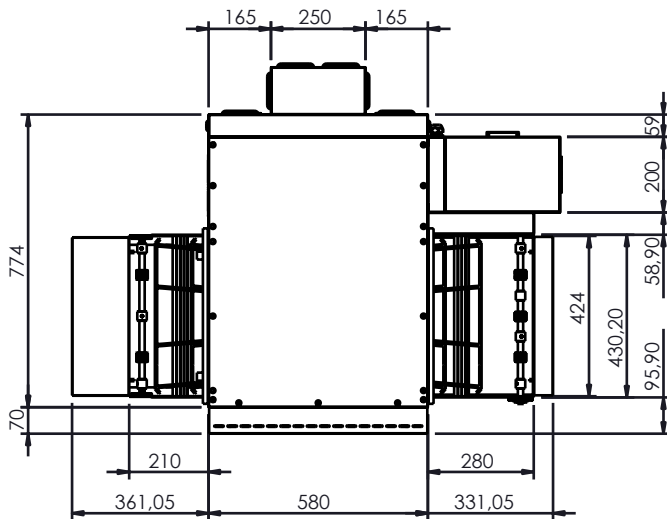

REAR

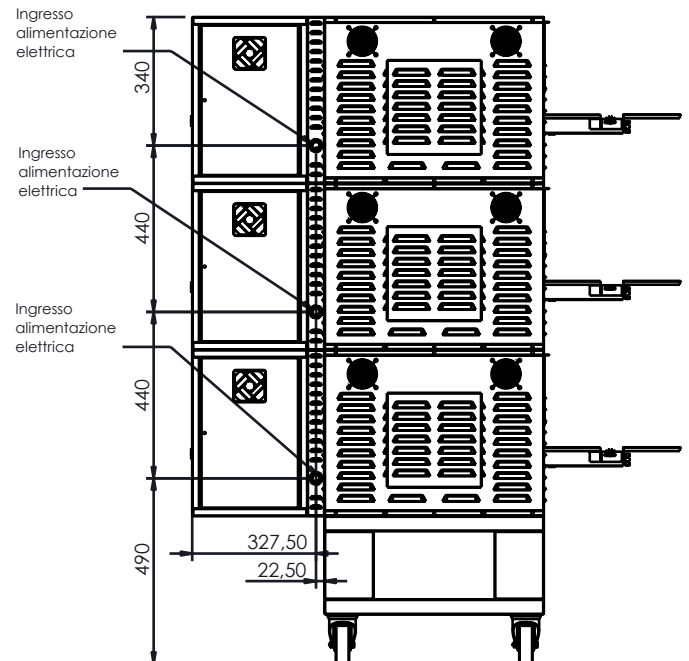

We reserve the right to alter specifications without notice.



THE
GOOD
LADY

Phone: 1800 183 818 Email: support@thegoodlady.com.au
Website: www.thegoodlady.com.au