

# SO F3

## bone saws



SO 1840 F3

- Simple and sturdy machines that are safe and easy to use.
- Stand-alone structure made out of cast anodized aluminium, shiny, hygienic and rustproof.
- Features a counter, meat pusher and serving slicer in stainless steel AISI 304.
- 24V controls with safety micro-switch on door, redundant ECU and motor brake (EC).
- Ease and precision in both horizontal and vertical adjustment of the upper pulley.
- Maximum blade adhesion to the pulley, thanks to the semi-curved shape of the pulleys and ideal adjustment.
- Sealed bearings on upper pulley.
- Smooth cleaning thanks to 2 special manufacturing details:
  - All the electrical parts are located beneath the work surface inside an appropriate IP 65 insulated box.
  - By simply unscrewing two knobs, you can remove the blade, upper pulley and its support, thereby making for a surface void of any encumbrance.
- Powerful asynchronous and ventilated 4-pole motors protected by sealing oil sump.
- Equipped with 16 mm tempered blades for cutting bones, frozen foods and fresh foods.

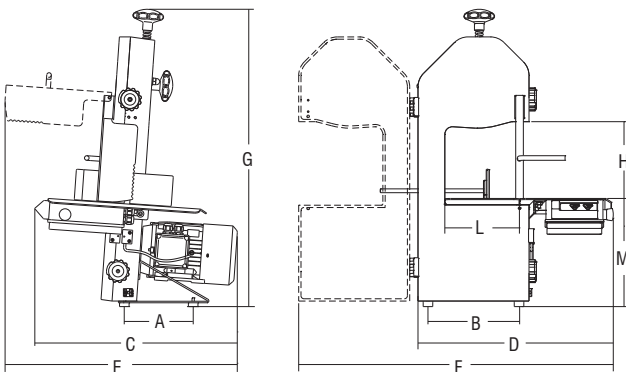

					A	B	C	D	E	F	G	H	L	M			
	mm	Hp/r.p.m.	mm	mm	mm	mm	mm	mm	mm	mm	mm	mm	mm	mm	kg	mm	kg
SO 1550 F3	1550	1ph 1,5/1.400 3ph 2/1.400	210	415x430	180	238	530	510	606	822	778	215	195	269	32	720x570x1200	44
SO 1650 F3	1650	1ph 1,5/1.400 3ph 2/1.400	210	445x485	180	300	530	600	640	950	915	249	200	305	39	720x570x1200	51
SO 1840 F3	1840	1ph 1,5/1.400 3ph 2/1.400	250	445x485	180	300	530	600	640	950	915	249	240	305	40	720x570x1200	52



SO 1650 F3



SO 1840 F3

