

# MIRRA VERTICAL

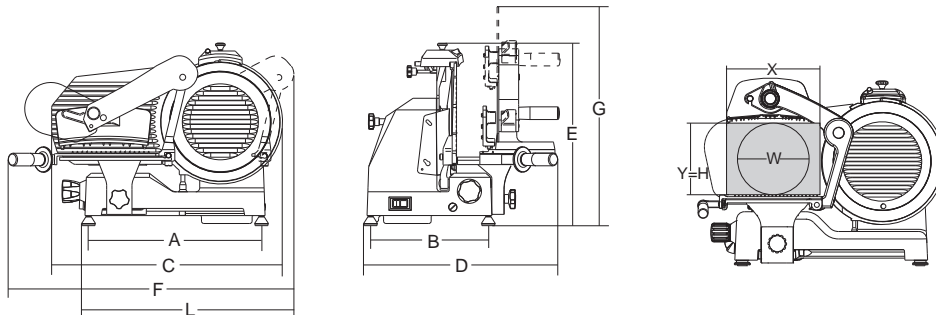

- Anodized cast aluminum alloy
- Great distance between blade and motor for easy cleaning
- Ventilated motor
- Forged, hardened large thickness blades
- Ground slide rod plate finished
- Stainless steel screws and slice deflector
- Strong thickness gauge support
- Cast-in sharpener assembly
- Compact dimensions but great cutting capacity
- Device for releasing the carriage on CE version

MIRRA 300 VERT. BS



	mm-inch	watt-Hp	mm	mm	mm	mm	mm	mm	mm	mm	mm	mm	mm	mm	mm	mm	mm	kg	mm	kg
Mirra 220 C Vert.	220/9"	147/0,20	13	225	230x235	400	260	500	535	400	570	405	475	205	150	150	150	16.5	600x500x500	19
Mirra 250 C Vert.	250/10"	147/0,20	13	230	230x235	400	260	510	535	410	570	410	475	205	170	170	170	17.5	600x500x500	20
Mirra 250 C Vert. BS	250/10"	147/0,20	13	215	275x260	400	260	510	480	415	700	600	540	270	190	190	190	21.5	600x500x500	24
Mirra 275 C Vert.	275/11"	147/0,20	13	220	230x235	400	260	530	535	420	570	425	465	225	205	205	205	18.5	600x500x500	21
Mirra 275 C Vert. BS	275/11"	147/0,20	13	225	275x260	400	260	530	480	420	700	770	540	270	200	200	200	22.5	600x500x500	25
Mirra 275 Vert. BS	275/11"	210/0,29	13	220	275x260	440	300	580	500	455	740	630	580	255	205	205	205	26	800x600x520	28.5
Mirra 300 Vert. BS	300/12"	210/0,29	13	265	275x260	440	300	585	540	460	740	770	580	255	215	215	215	27	800x600x520	29.5



MIRRA 250 C VERT.



Mirra 250-275 C VERT. BS



MIRRA 275 C VERT.