



MASTER

meat grinders - meat mixers



- AISI 304 stainless steel construction, can be sprayed.
- 2 independent IP x5 motors for grinder and mixer:
- 5 Hp or 7Hp meat grinder motors (42 model)
- 5 Hp or 7Hp meat grinder motors (42 model)
- 4 Hp meat grinder motor (32 model)
- Oil-bath, waterproof angular gear box
- Safety microswitch on meat mixer cover
- Air pistons open the cover
- IP 67 stainless steel controls (reverse available for grinder)
- **Grinding set:**
- Completely made of AISI 304 stainless steel
- Designed for high performance
- Stainless steel drive pin.
- Tempered steel worm pin.
- Grinding set and mixing arm can be easily disassembled without tools
- Exclusive, patented plate and knife detection system

Standard accessories:

- Stainless steel self-sharpening knife and 4,5 mm plate
- Floor support with stainless steel wheels and brake
- Worm and plate removing tool



MASTER 90 Y 12



MASTER 30 Y12



MASTER 60



> Optional: interlock protection for more than 8 mm holes plates.



Optional: splash guard



Lid with self lifting



Full Control system (for Format S-A)



Optional pedal controls



P. 121



Timer function

Reverse with timer for meat mixer

Optional connections for:

- pedal controls
- Format S - semi-automatic hamburger press attachment
- Format A - automatic hamburger press attachment.

Optional available:

- Stainless steel splash guard
 - mouth guard interlocked for plates with 8 > mm
 - Stainless steel 1/2 or total unger grinding set
- FULL CONTROL:**



MASTER 90 Y12 con FORMAT S



MASTER 90 Y12 con FORMAT A



Plates removal tool



Standard o enterprise 1/2 Unger Unger Totale



MASTER 90 Y 12

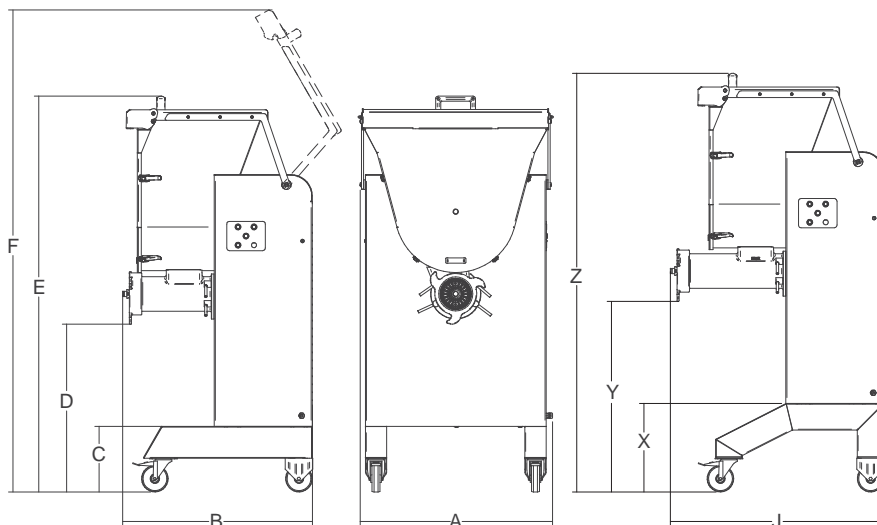

MASTER 90 Y12
optional high legs
X: 333 mm / Y: 717 mm
Z: 1575 mm / J: 806 mm

								A	B	C	D	E	F			
	watt/HP	watt/HP		kg/lt	ø mm	r.p.m.	kg/h.	mm	mm	mm	mm	mm	mm	kg	mm	kg
Master 30 Y12	2940/4	1102/1,5	1ph/3ph	30-42	4.5	TC200/IP30	600-850	644	658	247	589	1243	1477	140	870x840x1700	165
Master 60	2940/4	1102/1,5	1ph/3ph	60-80	4.5	TC186/IP30	850-1000	670	732	247	655	1416	1694	160	870x840x1700	185
Master 90 Hp 5 Y12	3675/5	1102/1,5	1ph/3ph	90-120	4.5	TC186/IP30	1000-1200	724	714	247	631	1489	1813	191	870x840x1700	216
Master 90 Hp 7 Y12	5145/7	1102/1,5	1ph/3ph	90-120	4.5	TC186/IP30	1000-1200	724	714	247	631	1489	1813	191	870x840x1700	216