

TAE101P3

BAKERY COMBI / PASTRY DECK COMBINATIONS

zanolli
1952 · ITALY

Main Features

HOOD

Exhaust Hood with Optional 400 or 600 mc³ Suction capacity.

BAKING CHAMBER

- 10 Trays Capacity (600 x 400)
- Large 80mm Tray Spacing
- Self cleaning
- Weekly Auto Start Up
- 147 Baking Programs
- 2 speed fan regulation
- Bi-directional reversing fan system
- Halogen light
- Convection Cooking
- Combination Cooking
- Steam Cooking
- Probe Cooking
- Touch Panel User Control
- Automatic Preheat
- 6 Cooking Cycles for each Program
- Digital Steam Exhaust Regulation
- Water injection regulation

DECK OVENS

- 1 x Teorema Polis Pastry Deck Ovens accommodating 2 x (600 x 400) Trays
- Stone / or steel base options
- Optional steam Boiler

PROVER

- 3 Trays Capacity (600 x 400)
- Large 75mm Tray Spacing
- Proofer with pan-holder
- Optional humidifier
- Door made of tempered glass
- Castor wheels with brakes

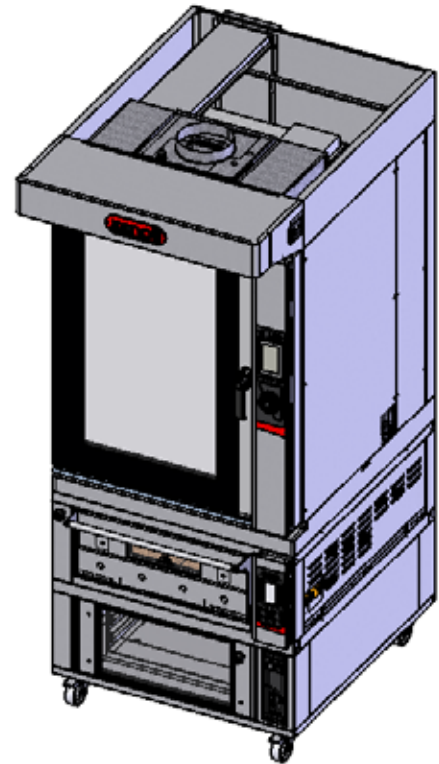

SPECIFICATIONS

Voltage	400V 3 Phase
Power	23.1 kw
Weight	385 kg
Plug Supplied	No
Capacity	10 Trays (400 x 600) for Anemos Bakery Combi 2 Trays (400 x 600) for Teorema Polis Pastry Deck Oven 3 Trays (400 x 600) for Proving Cabinet
Thermostat	260°C Teorema Anemos bakery Combi 400°C Teorema Polis Bakery Deck
Warranty	4 Year Warranty (2 yr Labour 4 yr Parts)

COMPONENTS

1 x Ventilation Hood Top	1COM019A
1 x 10 Tray TEOREMA Anemos 10E/MC TOUCH Bakery Combi Oven	5FC0503
1 x Stacking kit	1COM010A
1 x TPOLIS 2S 2 tray Bakery Deck Oven	2P02H05B
1 x 3 Tray Proving Cabinet with Humidifier on Castors	1COM009A

DIMENSIONS

External Width	970mm
External Depth	2347mm (including hood)
External Height	1351mm



Phone: 1800 183 818 Email: support@thegoodlady.com.au
Website: www.thegoodlady.com.au

TAE101P3

EXHAUST HOOD STRUCTURE AND PROVISION

FRONT

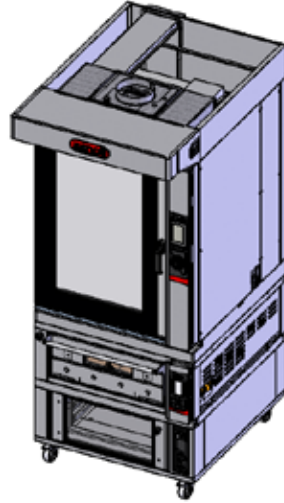
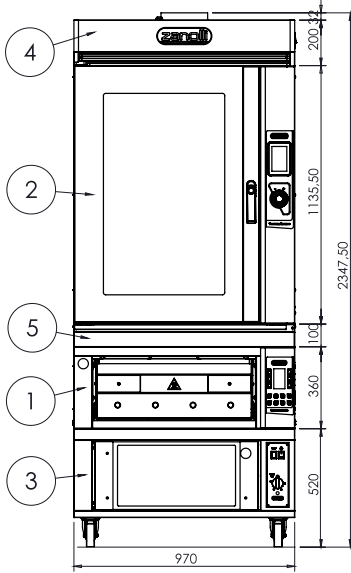

SIDE

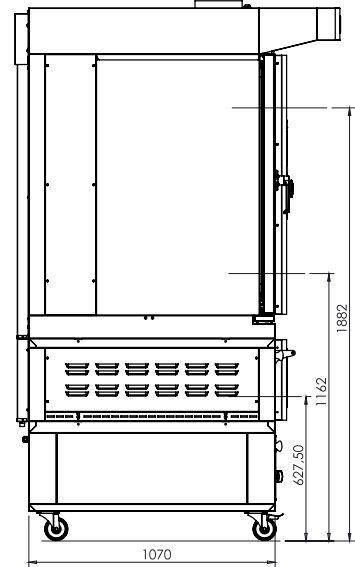

Item num.	Quantity	Description	Power	Trays	Distance between trays
5	1	KIT COMBI			
1	1	T POLIS 2S	6,4 kW	n°2	
2	1	T ANEMOS 10E TOUCH	15,7 kW	n°10	80mm
3	1	PROOFING CABINET	1 kW	n°6	75mm
4	1	EXHAUST HOOD	0,3 kW		
Optional		Power			
HUMIDIFIER FOR PROVING CABNIT		1 KW			
STEAM BOILER FOR DECK OVEN		2.8KW			

REAR

TOP

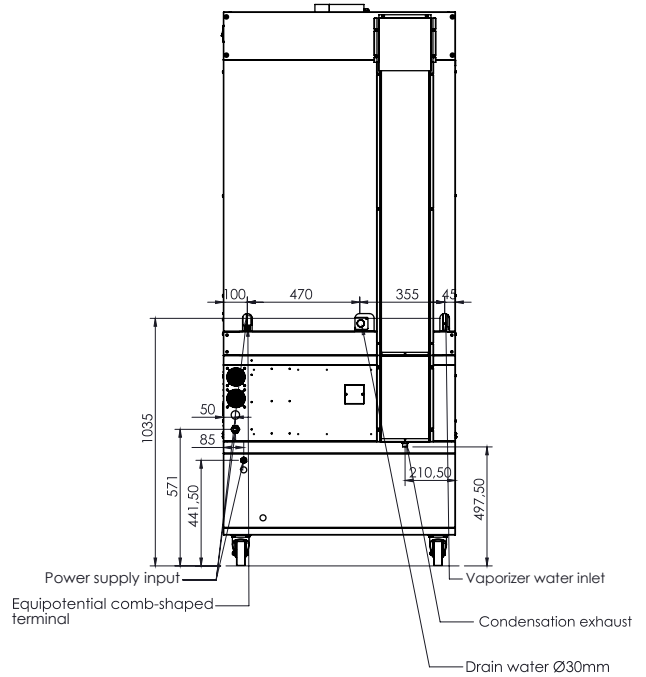
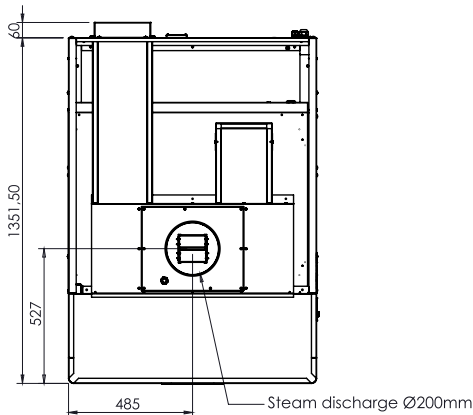

We reserve the right to alter specifications without notice.



Phone: 1800 183 818 Email: support@thegoodlady.com.au
 Website: www.thegoodlady.com.au

TAE101P3

EXHAUST HOOD STRUCTURE, PROVISION & MOTOR (400M3/600M3 CAPACITY)

FRONT

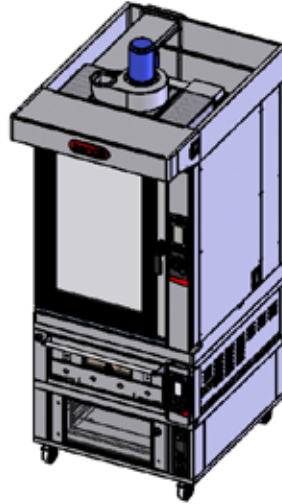
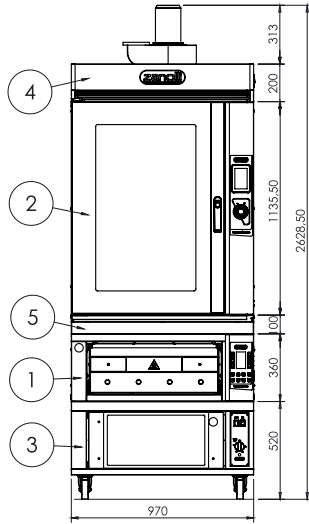

SIDE

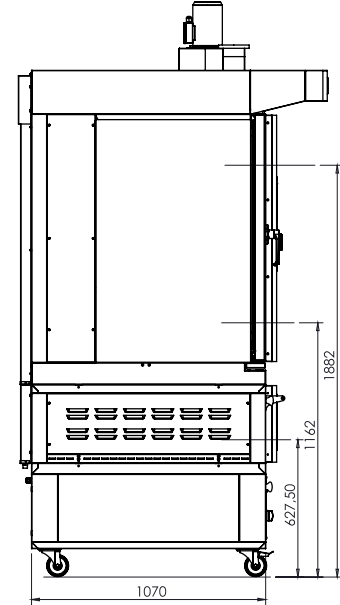

Item num.	Quantity	Description	Power	Trays	Distance between trays
1	1	T POLIS 2S	6.4 kW	n°2	
2	1	T ANEMOS 10 TOUCH	15.7 kW	n°10	80mm
3	1	PROOFING CABINET	1 kW	n°6	75mm
4	1	EXHAUST HOOD WITH MOTOR KIT COMBI	0.25 kW		
5	1				
Optional		Power			
HUMIDIFIER FOR PROVING CABNIT		1KW			
STEAM BOILER FOR DECK OVEN		2.8KW			

REAR

TOP

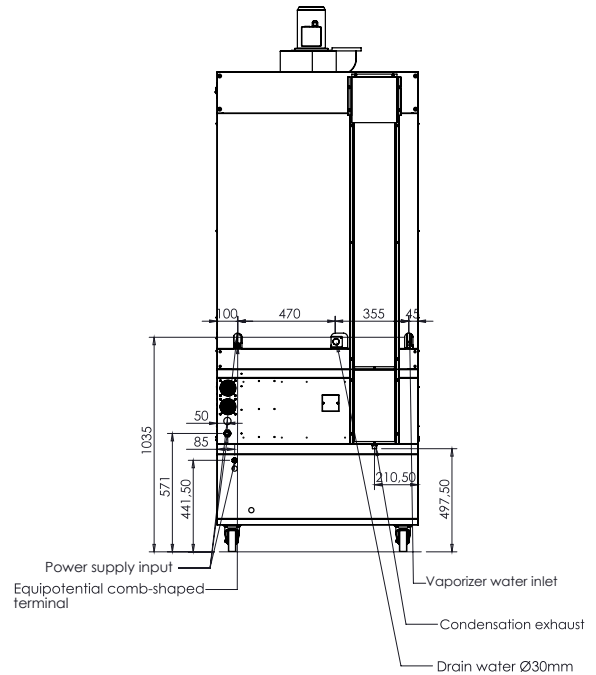
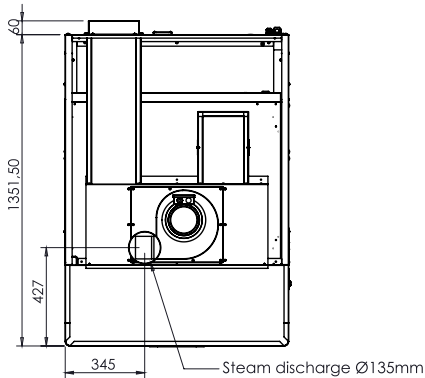

We reserve the right to alter specifications without notice.



Phone: 1800 183 818 Email: support@thegoodlady.com.au
 Website: www.thegoodlady.com.au

TAE101P3

NO EXHAUST PROVISION

FRONT

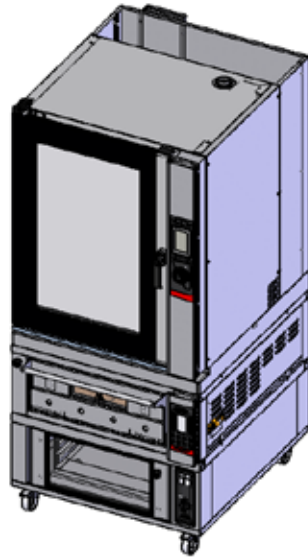
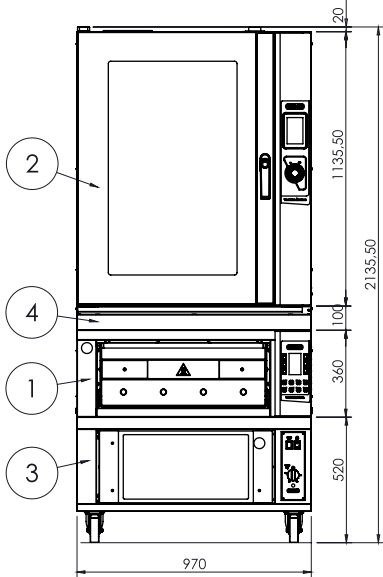

SIDE

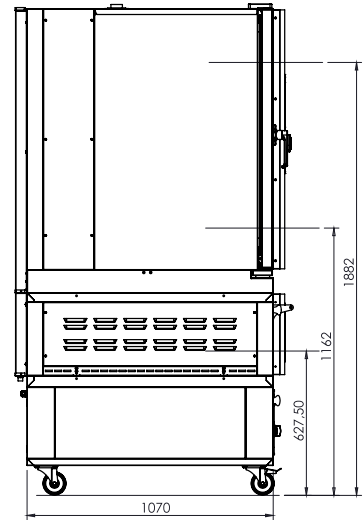

Item num.	Quantity	Description	Power	Trays	Distance between trays
1	1	T POLIS 2S	6.4 kW	n°2	
2	1	T ANEMOS 10E TOUCH	15.7 kW	n°10	80mm
3	1	PROOFING CABINET	1 kW	n°6	75mm
4	1	KIT COMBI			
Optional		Power			
HUMIDIFIER FOR PROVING CABNIT		1KW			
STEAM BOILER FOR DECK OVEN		2.8KW			

REAR

TOP

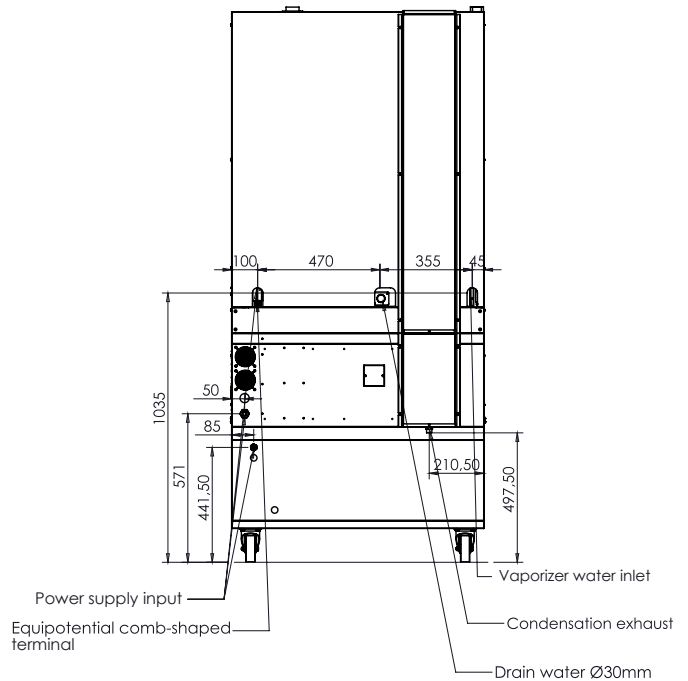
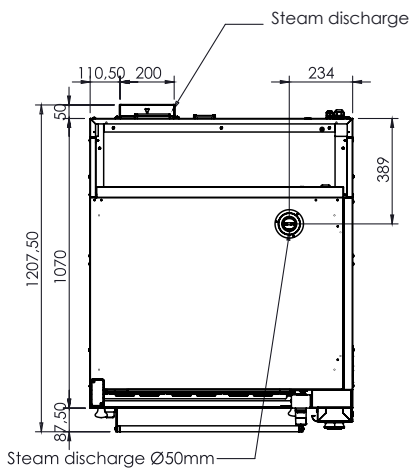

We reserve the right to alter specifications without notice.



Phone: 1800 183 818 Email: support@thegoodlady.com.au
 Website: www.thegoodlady.com.au